



2026 James Park Renovations and Pathway Improvements

Bid # 26-15

ADDENDUM No. 3

April 3, 2026

Any and all changes to the Contract Document are valid only if they are included by written addendum to all potential respondents, which will be mailed, emailed and/or faxed prior to the bid due date to all who are known to have received a complete bid document. Each respondent must acknowledge receipt of any addenda by indicating on the Bid Form. Each respondent, by acknowledging receipt of any addenda, is responsible for the contents of the addenda and any changes to the bid proposal therein. Failure to acknowledge receipt of any addenda may cause the bid to be rejected. If any language or figures contained in this addendum are in conflict with the original document, this addendum shall prevail.

This addendum consists of the following:

1. Addendum Number Three (3) is attached and consists of a total of sixteen (16) pages including the cover sheets. Any changes to the drawings or specifications noted within Addendum Number Three (3) will be reflected in subsequent drawing issues.

Please feel free to call (847-866-2910) or email (lithomas@cityofevanston.org) with any questions or comments.

Sincerely,

Linda Thomas
Purchasing Specialist

2026 James Park Renovations and Pathway Improvements

Bid # 26-15

ADDENDUM No. 3

April 3, 2026

This addendum forms a part of the Specifications and Bid Documents for Bid #26-15 and modifies these documents. This addendum consists of the following:

Exhibit A: - attached

Updated text on page 3 and 4. Renaming of Alternate 1 – Splash Pad and Alternate 2 – Splash Pad to text below

- Alternate 1 – Splash Pad (8) Zones, LED
- Alternate 1 – Splash Pad (2) Zones, Non-LED

Drawings:

Sheet (Cover) - attached

- Index of Drawings update to match specification section 01 00 00
- Existing Sewer Routing Map update to more accurately represent existing conditions.

Sheet C-05.2

- Note at drinking fountain on Field House. Paving elevation shall ensure that the drinking fountain meets ADA requirements.

Sheet C-06.0 - attached

- RPZ Enclosure update
- Cabinet enlargement update
- Addition of contact information for supplier

Sheet C-06.1 - attached

- RPZ Enclosure update
- Cabinet enlargement update
- Addition of contact information for supplier

Sheet S-1

- Structural base detail moved to sheet S-2.
- Wall elevation: Please note that all exposed edges shall have factory closed end finishes.

Sheet S-2 - attached

- New drawing: Defining Alternate 4 - Structural Base extents.

Specifications:

Change to Specification Section 129300, Site Furnishings, Part 2.7

2.7 "Coa receptacle" to be replaced with Coal Receptacle

Note: Acknowledgment of this Addendum is required in the Bid.

EXHIBIT A – BID FORM
For
2026 James Park Renovations and Pathway Improvements
(BID #26-15)

1.01 BID TO:

THE CITY OF EVANSTON

909 Davis Street
Evanston, Illinois 60201

Hereinafter called "OWNER".

1.02 BID FROM:

(Hereinafter call "BIDDER")

Address

Telephone Number

Fax Number

1.03 BID FOR: **2026 JAMES PARK RENOVATIONS AND PATHWAY IMPROVEMENTS**

1.04 ACKNOWLEDGEMENT:

A. The Bidder, in compliance with the Invitation for Bids, having carefully examined the Drawings and Project Manual with related documents and having visited the site of the proposed Work, and being familiar with all of the existing conditions and limitations surrounding the construction of the proposed project, including the structure of the ground, subsurface conditions, the obstacles which may be encountered, local restrictions, and all other relevant matters concerning the Work to be performed, hereby PROPOSES to perform everything required to be performed, and to provide all labor, materials, necessary tools and equipment, expendable equipment, all applicable permits and taxes and fees, and provide all utility and transportation services necessary to perform and complete in a workmanlike

manner the Project in accordance with all the plans, specifications and related Contract Documents as prepared by the City of Evanston.

- B. The undersigned hereby acknowledges receipt of Invitation of Bids, Instruction to Bidder, the Project Manual, Drawings, and other Contract Documents and acknowledges receipt of the following Addenda:

Addendum No. _____ Dated _____

Addendum No. _____ Dated _____

Addendum No. _____ Dated _____

1.05 GENERAL STATEMENTS

- A. The undersigned has checked all of the figures contained in this proposal and further understands that the Owner will not be responsible for any errors or omissions made therein by the undersigned.
- B. It is understood that the right is reserved by the Owner to reject any or all proposals, to waive all informality in connection therewith and to award a Contract for any part of the work or the Project as a whole.
- C. The undersigned declares that the person(s) signing this proposal is/are fully authorized to sign on behalf of the named firm and to fully bind the named firm to all the conditions and provisions thereof.
- D. It is agreed that no person(s) or company other than the firm listed below or as otherwise indicated hereinafter has any interest whatsoever in this proposal or the Contract that may be entered into as a result thereof, and that in all respects the proposal is legal and fair, submitted in good faith, without collusion or fraud.
- E. It is agreed that the undersigned has complied and/or will comply with all requirements concerning licensing and with all other local, state and national laws, and that no legal requirement has been or will be violated in making or accepting this proposal, in awarding the Contract to him, and/or in the prosecution of the Work required hereunder.
- F. To be considered a bona fide offer, this proposal must be completed in full and accompanied by a bid deposit or a bid bond when required by Contract Documents or Addenda.

1.06 ALTERNATES

- A. When alternate proposals are required by Contract Documents or Addenda thereto, the undersigned proposes to perform alternates for herein stated additions to or deductions from hereinbefore stated Base Bid. Additions and deductions include all modifications of Work or additional Work that the undersigned may be required to perform by reason of the acceptance of alternates.

1.07 ALLOWANCE

A. The allowance is intended to address items not able to be precisely determined prior to bidding including unforeseen conditions that are discovered during the course of construction. At the end of the project, unspent allowance shall be credited to owner via change order. See Section 01 21 00 – Allowances for additional information.

1.08 AGREEMENT

- A. In submitting this Bid, the undersigned agrees:
 - 1. To hold this Bid open for sixty (60) days from submittal date.
 - 2. To enter into and execute a Contract with the Owner within ten (10) days after receiving Notice of Award from the Owner.
 - 3. To accomplish the work in accordance with the Contract Documents.
 - 4. To complete the work by the time stipulated in the General Conditions
- B. The Owner reserves the right to reject any and all Bids and to waive any informalities in Bidding.

1.09 SCHEDULE

A. See General Conditions for required schedule of completion dates.

1.10 PROPOSED PRICES

A. The Bidder hereby proposes to furnish all labor, materials, equipment, transportation, construction plant and facilities necessary to complete, in a workmanlike manner and in accordance with the contract documents, the contract of work bid upon herein for compensation in accordance with the following prices:

BASE BID AMOUNT: \$ _____

ALLOWANCE (ADDITIONAL WORK – GENERAL): \$ _____ +80,000

TOTAL BASE BID AMOUNT: \$ _____

ALTERNATE 1 – SPLASH PAD (8) Zones, LED

This alternate adds an (8) zone splash pad with LED jets to the center playground area as depicted in the construction documents. The ADD/DEDUCT LUMP SUM PRICE, if awarded to the undersigned, shall be:

ALTERNATE 1 AMOUNT: \$ _____

ALTERNATE 2 – SPLASH PAD (2) Zones, Non-LED

This alternate adds a (2) zone splash pad with non-LED jets to the center playground area as depicted in the construction documents. The ADD/DEDUCT LUMP SUM PRICE, if awarded to the undersigned, shall be:

ALTERNATE 2 AMOUNT: \$ _____

ALTERNATE 3 – HILLSIDE PLANTINGS

This alternate adds the hillside soil top dressing and associated seeding area as depicted in the construction documents. The ADD/DEDUCT LUMP SUM PRICE, if awarded to the undersigned, shall be:

ALTERNATE 3 AMOUNT: \$ _____

ALTERNATE 4 – SOIL STABILIZATION

This alternate adds a structural base to select paving areas as depicted in the construction documents. The ADD/DEDUCT LUMP SUM PRICE, if awarded to the undersigned, shall be:

ALTERNATE 4 AMOUNT: \$ _____

1.11 BID SECURITY

If required by the bid documents, a scanned copy of the bid bond must be included with the bid electronic submission. The City is currently not able to accept a certified check, bank cashier's check or electronic bid bond at this time.

- A. The City of Evanston Civic Center is unable to receive in person drop-off and it is closed to the public. The original bid bond must be mailed within ten (10) days after the due date, to the City of Evanston Purchasing Department, 909 Davis Street, Evanston, Illinois 60201 Attention Purchasing Manager using the USPS (certified or priority), UPS or FedEx mail options in order to have a tracking number.
- B. Accompanying this electronic submittal is a scanned copy of a bank draft, bid bond, Cashier's check or Certified check as surety in the amount of not less than five percent (5%) of the Total Bid payable to the City of Evanston.

The amount of the check or draft is: \$ _____

If this bid is accepted and the undersigned shall fail to execute a contract and contract bond as required it is hereby agreed that the amount of the check or draft or bidder's bond substituted in lieu thereof, shall become the property of the City and shall be considered as payment of damages due to delay and other causes suffered by the City because of the failure to execute said contract and contract bond; otherwise said check or draft shall be returned to the undersigned.

In the event that one check or draft is intended to cover two or more bids, the amount must be equal to the sum of the project proposal guarantees of the individual sections covered.

If the check or draft is placed on another project proposal, state below where it may be found, as follows: The check or draft will be found in the project proposal for:
_____.

1.12 PERFORMANCE/PAYMENT BOND

The undersigned bidder agrees to provide Performance Bond and Payment Bond executed in accordance with Contract Performance Bond form furnished by and acceptable to the Owner written with _____

_____ in the amount of 100% of the Contract Sum (Total Base Bid and all accepted alternatives and adjustments) the cost of which is included in the Bid.

Cost of bond for change order is _____ percent of change order cost.

1.13 LIQUIDATED DAMAGES

The undersigned Bidder understands and agrees to the provisions stated under "LIQUIDATED DAMAGES" in the General Conditions and shall be assessed at the specified daily rate for each calendar day or partial calendar day until completion as defined herein.

1.14 MATERIAL SUBSTITUTION SHEET

The following is a schedule of substitute materials I propose to furnish on this job, with the difference in price being added to or deducted from the Base Bid. The Base Bid is understood to include only those items which are definitely specified by trade names or otherwise.

I understand that if no price difference is indicated, then the selection of materials is optional with the Owner, and approval or rejection of the substitution below will be indicated prior to signing of Contracts.

<u>PRODUCT NAME AND/OR MANUFACTURER</u>	<u>ADD</u>	<u>DEDUCT</u>
_____	_____	_____
_____	_____	_____
_____	_____	_____

1.15 PROPOSAL SIGNATURE (REQUIRED)

A. SOLE PROPRIETOR

Signature of Bidder: _____

SUBSCRIBED AND SWORN to before me this ____ day of ____, 20__

Notary Public

Commission Expires: _____

B. PARTNERSHIP

Signature of All Partners: _____

Name (typed or printed)

Name (typed or printed)

SUBSCRIBED AND SWORN to before me this ____ day of ____, 20__

Commission Expires: _____

Notary Public

C. CORPORATION

Signature of Authorized Official: _____

Title: _____

Name above (typed or printed): _____

(If other than the president, attach a certified copy of that section of corporate by-laws or other authorization by the Corporation which permits the person to execute the offer for the Corporation.)

(Corporate Seal)

Attest: _____

Secretary

SUBSCRIBED AND SWORN to before me this ____ day of ____, 20__

Commission Expires: _____

Notary Public

1.16 DISCLOSURE

- A. The undersigned duly sworn deposes and says on oath that the bidder has withheld no disclosures of ownership interest and the information provided herein to the best of its knowledge is current and said undersigned has not entered into any agreement with any other bidder or prospective bidder or with any other person, firm or corporation relating to the price named in said proposal or any other proposal, nor any agreement or arrangement under which any person, firm or corporation is to refrain from bidding, nor any agreement or arrangement for any act or omission in restraint of free competition among bidders and has not disclosed to any person, firm or corporation the terms of this bid or the price named herein.

Bidder: _____

Business Address: _____

Telephone Number: _____

1.17 CONTACTS

- A. In the event the Evanston City Council approves this bid response, list the name, address, telephone, and fax number of the person to be contacted:

Bidder: _____

Address: _____

Telephone Number: _____

Fax Number: _____

1.18 REFERENCES

A. Provide three (3) references for which your firm has completed work of a similar scope in the past.

1. Name: _____
Address: _____
Contact Person: _____
Phone: _____
Contract Value: _____
Contract Dates: _____

2. Name: _____
Address: _____
Contact Person: _____
Phone: _____
Contract Value: _____
Contract Dates: _____

3. Name: _____
Address: _____
Contact Person: _____
Phone: _____
Contract Value: _____
Contract Dates: _____

2026 JAMES PARK RENOVATIONS AND PATHWAY IMPROVEMENTS

300 DODGE AVENUE, EVANSTON, IL 60202
(BID #26-15)

OWNER

CITY OF EVANSTON
PUBLIC WORKS AGENCY
CONTACT: KENON BOEHM
909 DAVIS STREET
EVANSTON, ILLINOIS 60201
224-296-4453 (PHONE)
kboehm@cityofevanston.org

NOTE

THE EXACT LOCATION OF ALL UTILITIES SHALL BE VERIFIED BY THE CONTRACTOR PRIOR TO CONSTRUCTION ACTIVITIES FOR UTILITY LOCATION CALL J.U.L.I.E. 1-800-892-0123, CITY OF EVANSTON UTILITIES DIVISION 847-866-2945, AND CITY OF EVANSTON FACILITIES MANAGEMENT DIVISION 847-448-8181.

LOCATION MAP

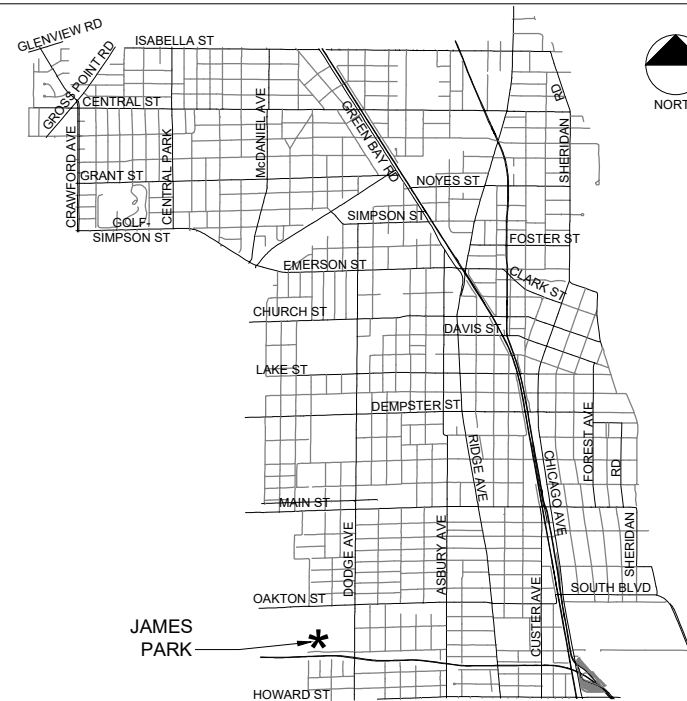

SEWER ROUTING MAP

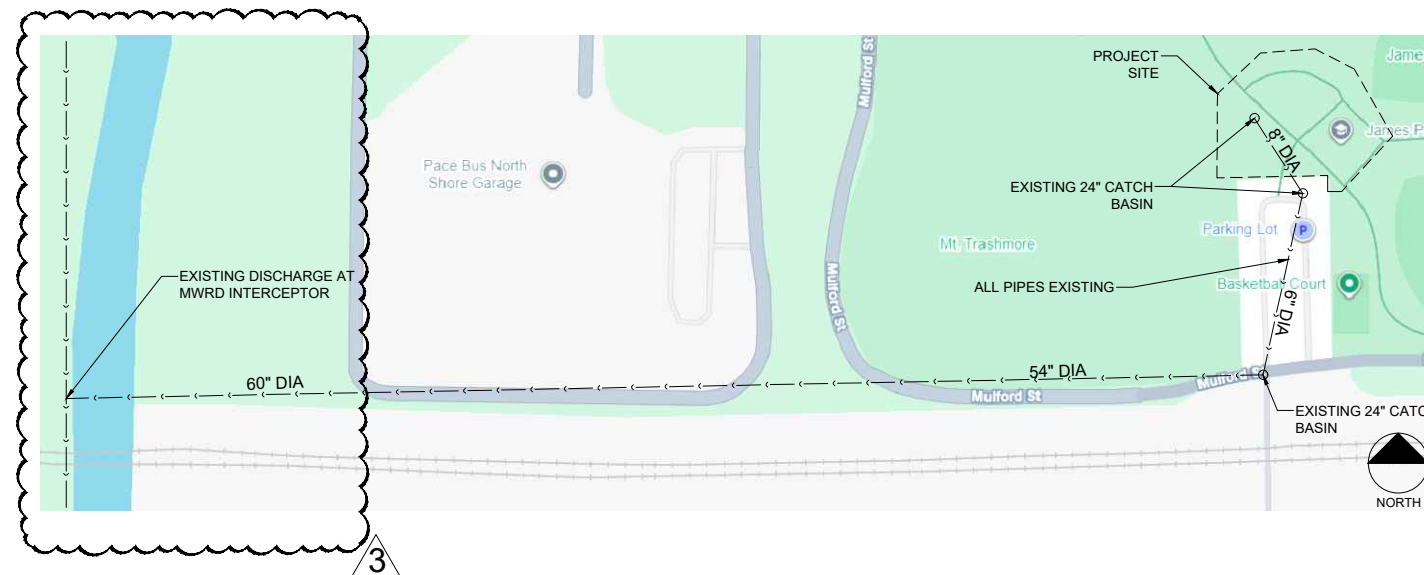

Contact the Metropolitan Water Reclamation District of Greater Chicago 2 days before starting work.

P (708) 588-4055
E WMOJobStart@mwr.org

DRAINAGE CERTIFICATION:

STORMWATER FLOWS AND VELOCITIES WILL NOT INCREASE EITHER UPSTREAM OR DOWNSTREAM AS A RESULT OF THE PROPOSED DEVELOPMENT.

INDEX OF DRAWINGS

DRAWING NO.	DRAWING TITLE
---	COVER SHEET
G-01	JAMES PARK LOCATION PLAN AND NOTES
G-02	GENERAL NOTES - MWRD
R-01	REGIONAL DEMOLITION PLAN
R-02	PATHWAY DEMOLITION PLAN
R-03	PATHWAY DEMOLITION PLAN
R-04	PATHWAY DEMOLITION & TRANSPLANT PLAN
R-05	FIELD HOUSE DEMOLITION & TRANSPLANT PLAN
DR-01	FIELD HOUSE UTILITY PLAN
DR-02	DRAINAGE AREAS
C-01	REGIONAL SITE PLAN
C-02	PATHWAY SITE PLAN
C-03	PATHWAY SITE PLAN
C-04	PATHWAY SITE PLAN
C-05	FIELD HOUSE SITE PLAN
C-05.1	FIELD HOUSE DIMENSION PLAN
C-05.2	FIELD HOUSE GRADING PLAN
C-05.3	PLAYGROUND LAYOUT PLAN
C-06	SPLASH PAD ALTERNATE 1
C-06.1	SPLASH PAD ALTERNATE 2
IR-01	IRRIGATION PLAN
IR-02	IRRIGATION PLAN CONT.
PP-01	WEST PATH PROFILE
PP-02	EAST PATH PROFILE
PP-03	EAST PATH PROFILE CONT.
P-01	SOILS PLAN
P-02	PLANTING PLAN - TREES
P-02.1	PLANTING PLAN - SHRUB AND HERBACEOUS
P-02.2	PLANTING PLAN - HILLSIDE ALTERNATE 3
D-01	DETAILS
D-02	DETAILS
D-03	DETAILS
D-04	DETAILS
D-05	DETAILS
D-06	DETAILS
S-0	STRUCTURAL - GENERAL NOTES
S-1	STRUCTURAL - RETAINING WALL PLAN AND ELEVATION
S-2	STRUCTURAL - STRUCTURAL BASE ALTERNATE 4
X-01	WEST PATH CROSS SECTIONS
X-02	EAST PATH CROSS SECTIONS

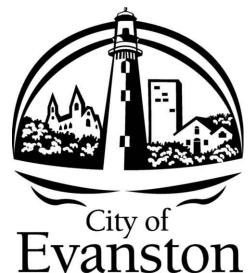

City of Evanston
Public Works Agency

SPLASHPAD NOTES

1. ALL WORK AND OPERATIONS SHALL COMPLY WITH ALL APPLICABLE FEDERAL, STATE AND LOCAL CODES AND ORDINANCES.
2. ALL SPLASHPAD PLUMBING AND ELECTRIC WORK TO BE PERFORMED AS DELEGATED DESIGN WITH FINAL DRAWING APPROVAL FROM MANUFACTURER.
3. CONTRACTOR TO CONTACT BILL PATTERSON WITH PLAY ILLINOIS FOR RAINDROP ACCESSORIES. BPATTERSON@PLAYIL.COM 773-682-3350



Public Works Agency
909 Davis Street
Evanston, Illinois 60201

KEYPLAN:

PROJECT NAME:

**2026 JAMES PARK
RENOVATIONS AND
PATHWAY
IMPROVEMENTS**

NOTES:

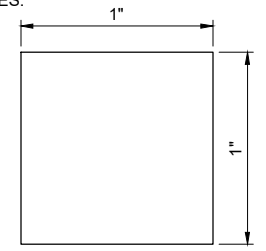

DO NOT SCALE DRAWINGS. WHEN PRINTED TO THE CORRECT SCALE, THE BOX ABOVE MEASURES 1" x 1".

DRAWING SCALE: AS SHOWN

REVISIONS:

	2026.03.11 / ISSUE FOR BID
1	2026.03.25 / ADDENDUM 1
2	2026.03.26 / ADDENDUM 2
3	2026.04.01 / ADDENDUM 3

SHEET TITLE

**SPLASHPAD
ALTERNATE 1
PLAN**

SHEET NO.

C-06

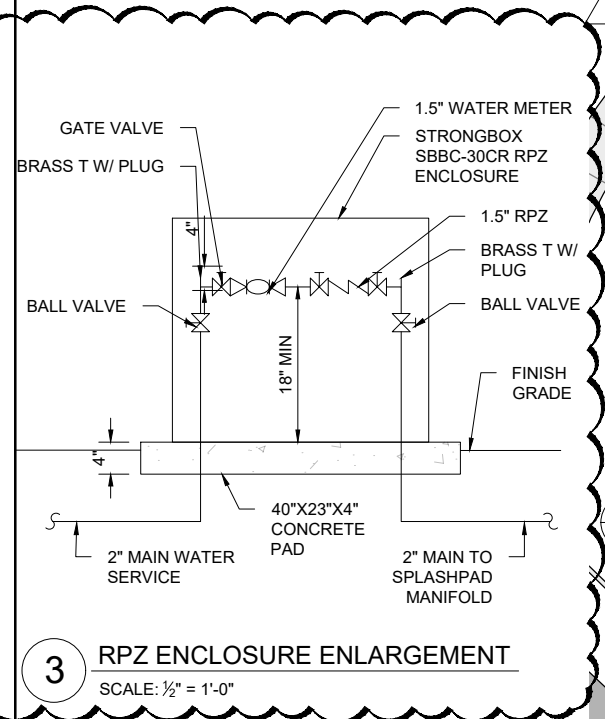
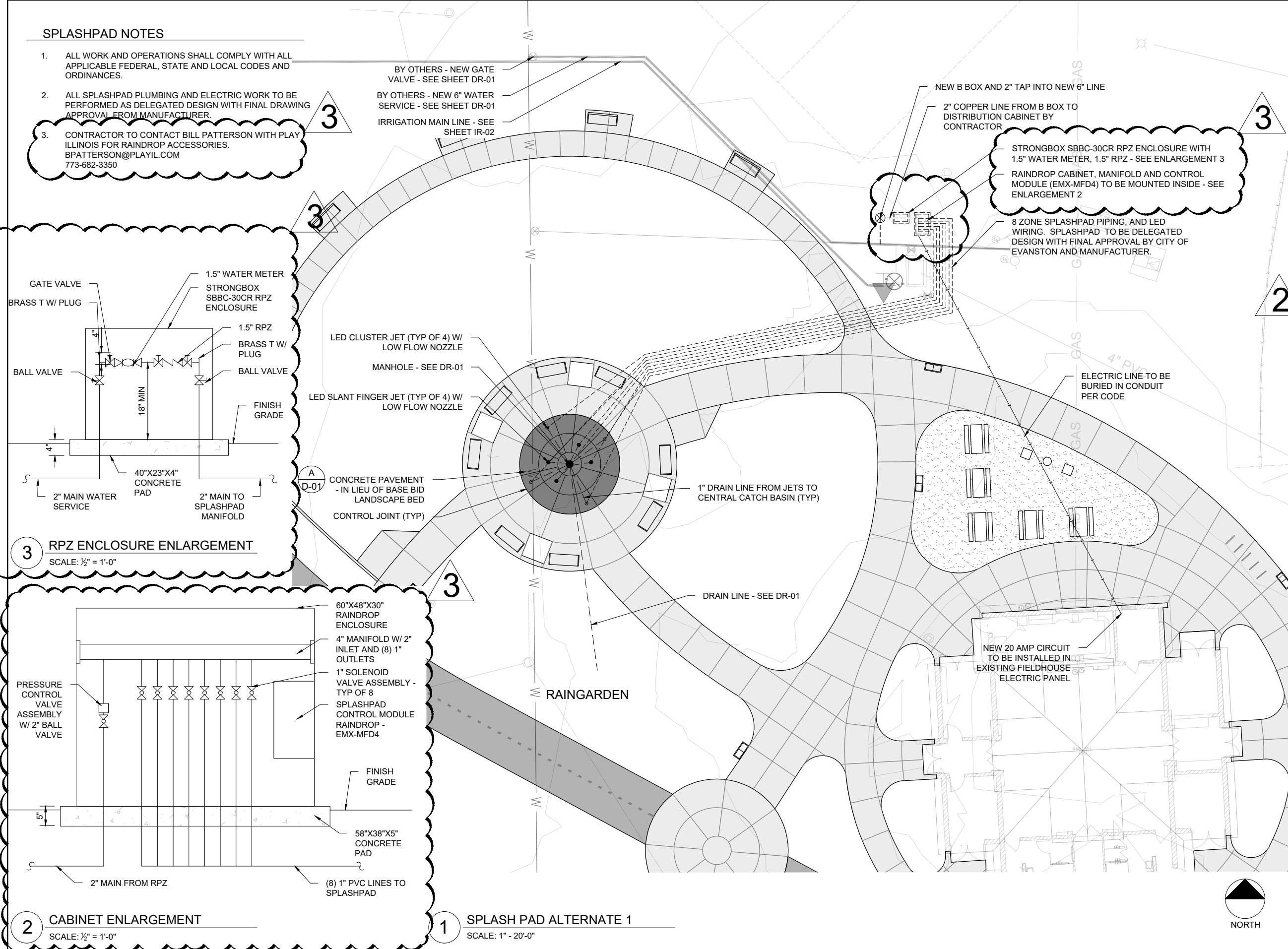

3 RPZ ENCLOSURE ENLARGEMENT
SCALE: 1/2" = 1'-0"

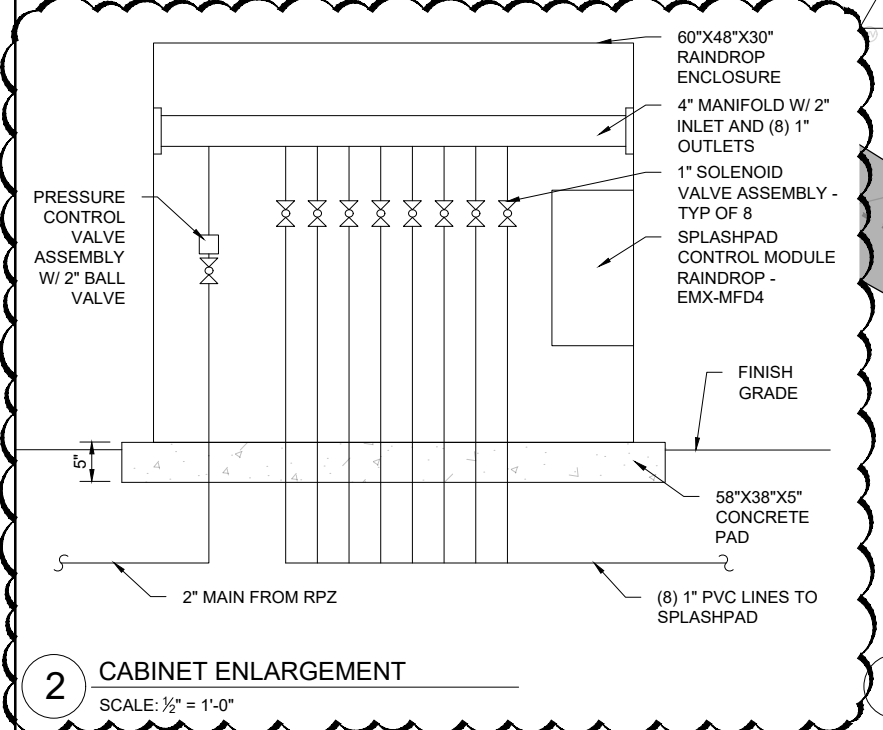

2 CABINET ENLARGEMENT
SCALE: 1/2" = 1'-0"

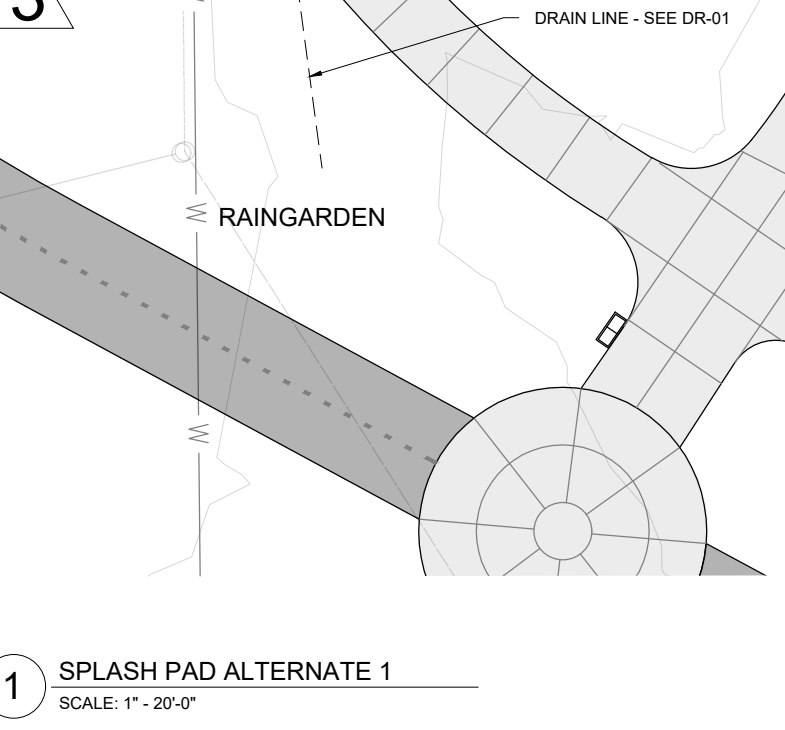

1 SPLASH PAD ALTERNATE 1
SCALE: 1" = 20'-0"



SPLASHPAD NOTES

1. ALL WORK AND OPERATIONS SHALL COMPLY WITH ALL APPLICABLE FEDERAL, STATE AND LOCAL CODES AND ORDINANCES.
2. ALL SPLASHPAD PLUMBING AND ELECTRIC WORK TO BE PERFORMED AS DELEGATED DESIGN WITH FINAL DRAWING APPROVAL FROM MANUFACTURER.
3. CONTRACTOR TO CONTACT BILL PATTERSON WITH PLAY ILLINOIS FOR RAINDROP ACCESSORIES. BPATTERSON@PLAYIL.COM 773-682-3350

BY OTHERS - NEW GATE VALVE - SEE SHEET DR-01
 BY OTHERS - NEW 6" WATER SERVICE - SEE SHEET DR-01
 IRRIGATION MAIN LINE - SEE SHEET IR-02

NEW B BOX AND 2" TAP INTO NEW 6" LINE
 2" COPPER LINE FROM B BOX TO DISTRIBUTION CABINET BY CONTRACTOR

STRONGBOX SBBC-30CR RPZ ENCLOSURE WITH 1.5" WATER METER, 1.5" RPZ - SEE ENLARGEMENT 3
 RAINDROP CABINET AND TIMER TO BE MOUNTED INSIDE - SEE ENLARGEMENT 2

(2) ZONE SPLASHPAD PIPING: SPLASHPAD TO BE DELEGATED DESIGN WITH FINAL APPROVAL BY CITY OF EVANSTON AND MANUFACTURER.

ELECTRIC LINE TO BE BURIED IN CONDUIT PER CODE

NEW 20 AMP CIRCUIT TO BE INSTALLED IN EXISTING FIELDHOUSE ELECTRIC PANEL

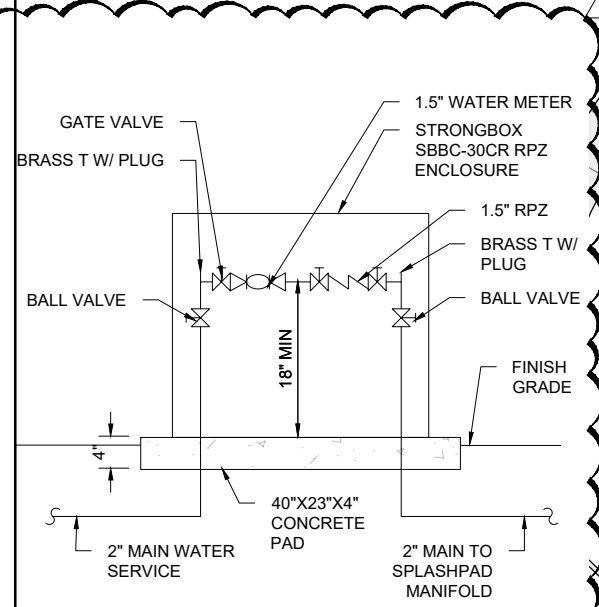

3 RPZ ENCLOSURE ENLARGEMENT
 SCALE: 1/2" = 1'-0"

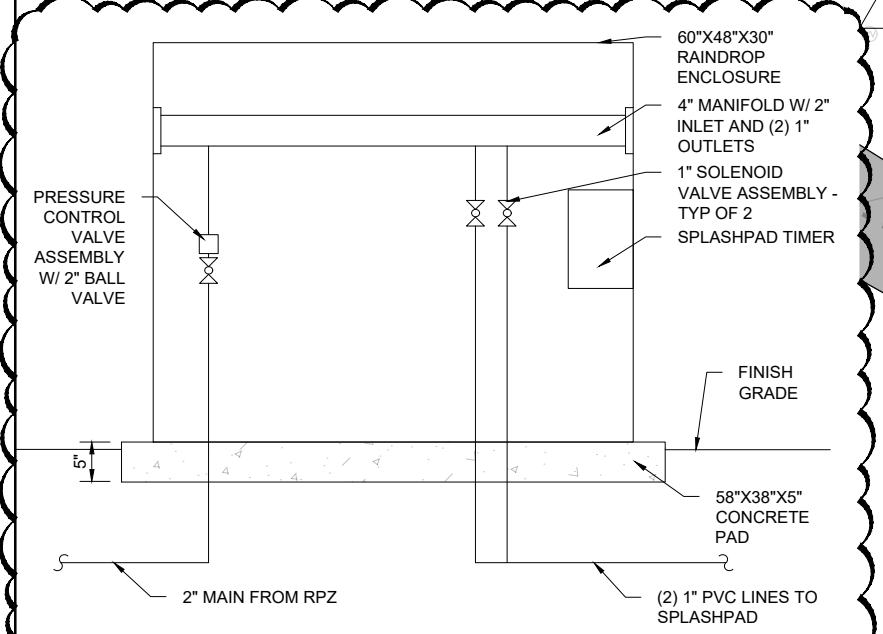

2 CABINET ENLARGEMENT
 SCALE: 1/2" = 1'-0"

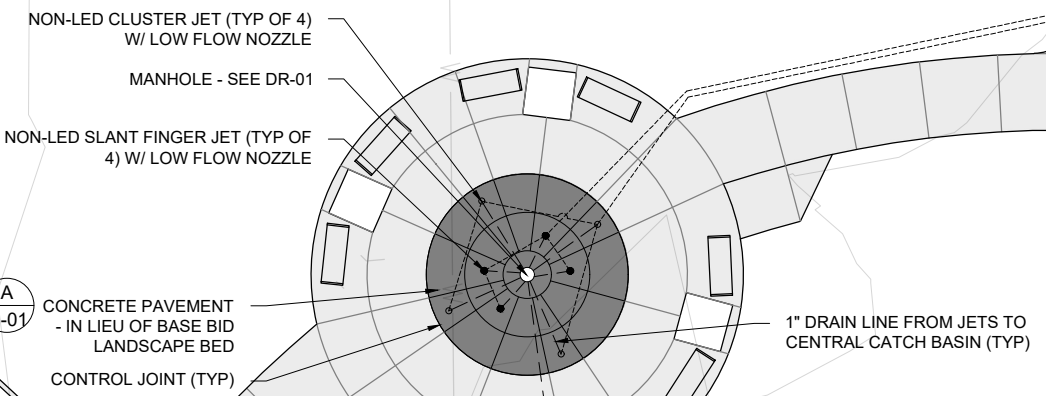

1 SPLASH PAD ALTERNATE 2
 SCALE: 1" = 20'-0"

KEYPLAN:
 PROJECT NAME:

2026 JAMES PARK RENOVATIONS AND PATHWAY IMPROVEMENTS

NOTES:

 DO NOT SCALE DRAWINGS. WHEN PRINTED TO THE CORRECT SCALE, THE BOX ABOVE MEASURES 1" x 1".

DRAWING SCALE: AS SHOWN

REVISIONS:

	2026.03.11 / ISSUE FOR BID
1	2026.03.25 / ADDENDUM 1
2	2026.03.26 / ADDENDUM 2
3	2026.04.01 / ADDENDUM 3

SHEET TITLE
SPLASHPAD ALTERNATE 2 PLAN

SHEET NO.
C-06.1

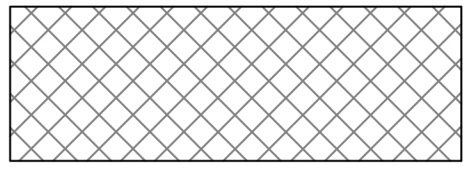

SOIL INDEX			
SYMBOL	DESCRIPTION	DEPTH	DETAIL
	STRUCTURAL CONCRETE BASE PREP- ALTERNATE 4	29"	D-1/S-2

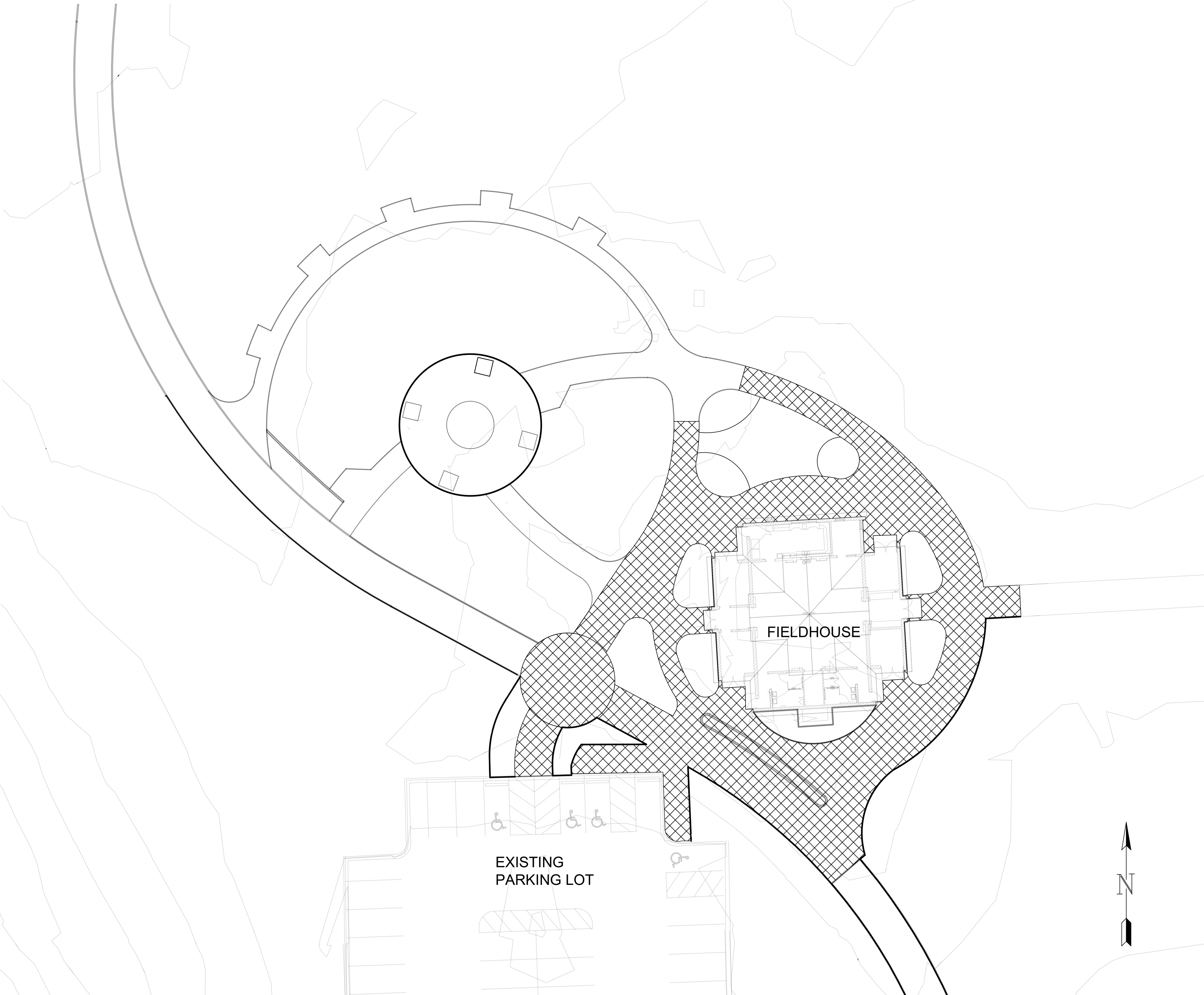

SUBGRADE PREP PLAN- ALTERNATE 4
1" = 20'

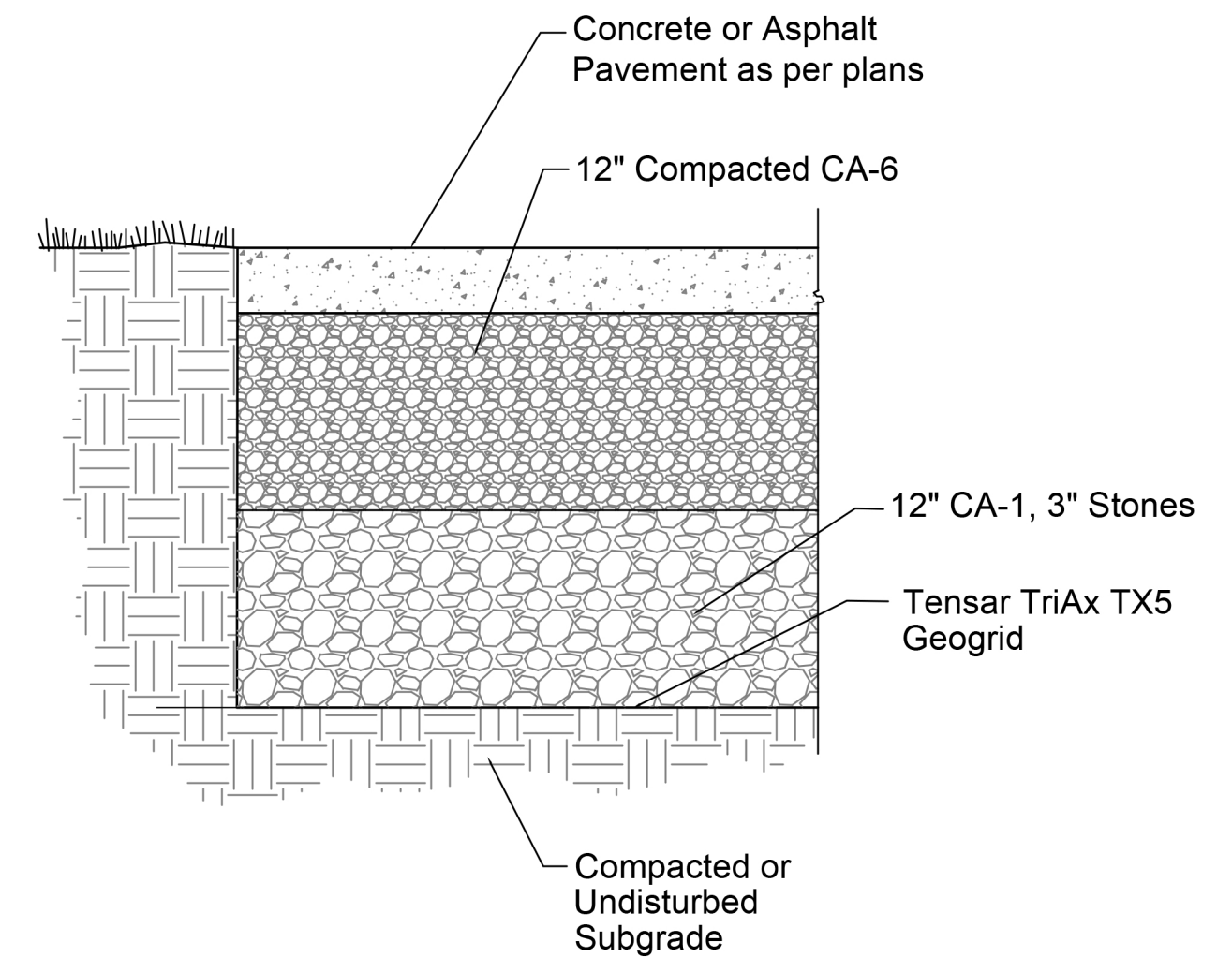

- NOTES:**
- SEE DETAIL B SHEET D-01 FOR JOINTS.
 - CONTRACTOR SHALL PLACE CONTROL JOINTS EVERY 5' AND EXPANSION JOINTS EVERY 25' OR AS SHOWN ON PLANS.

D-1 CONCRETE PAVEMENT W/ STR. BASE
NOT TO SCALE

3

2

REVISIONS	
NO.	DATE: DESCRIPTION:
1	03/26/2026 ADDENDUM 1
2	03/26/2026 ADDENDUM 2
3	04/01/2026 ADDENDUM 3

GSG CONSULTANTS, INC.
735 E. REMINGTON RD. SCHAUMBURG, IL 60173
TEL: +1630.994.2600 | WWW.GSG-CONSULTANTS.COM
ILLINOIS PROFESSIONAL DESIGN FIRM# 184-002852



2026 JAMES PARK RENOVATIONS AND PATHWAY IMPROVEMENTS- STR. BASE ALTERNATE 4
300 DODGE AVENUE
EVANSTON, IL

DRAWN BY:	PROJECT:
SD	26-4004
CHECKED BY:	SCALE:
SN	VP SCALE
DATE:	SHEET:
04/01/2026	3 OF 3
SHEET NO:	
S-2	

